

FB300 Fixed Banner Arm



The FB300 Fixed Banner Arm is designed to securely hold banners in place, providing a stable and reliable solution for pole-mounted banner displays. Its fixed design helps keep banners properly positioned while supporting everyday outdoor conditions. The FB300 Fixed Banner Arm can be made to any length and is available in a galvanized or zinc-plated powder-coated finish.



Proud

Classic Displays

Right for you since 1977

FB300 Fixed Banner Arm

Product Data Sheet



Materials:

-Galvanized or zinc-plated powder coated steel

Features:

-Integrated mounting bracket to accommodate most utility poles
-Bracket features four 1" eyelets for threading banding

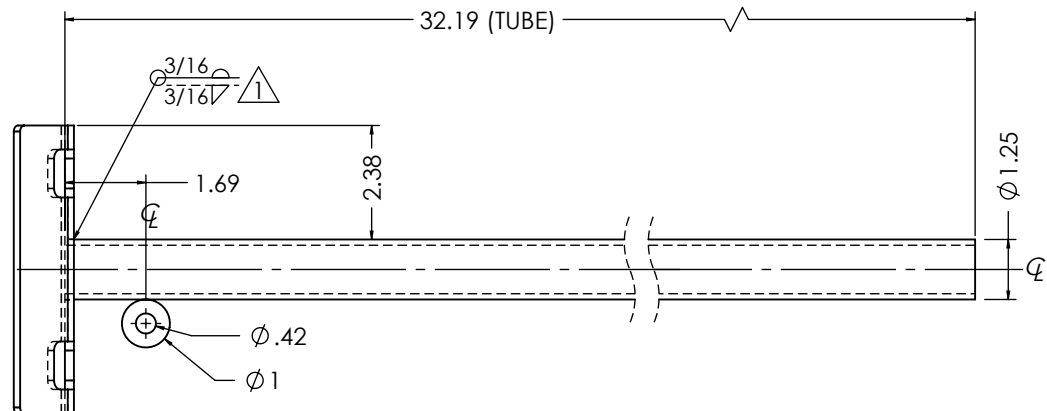
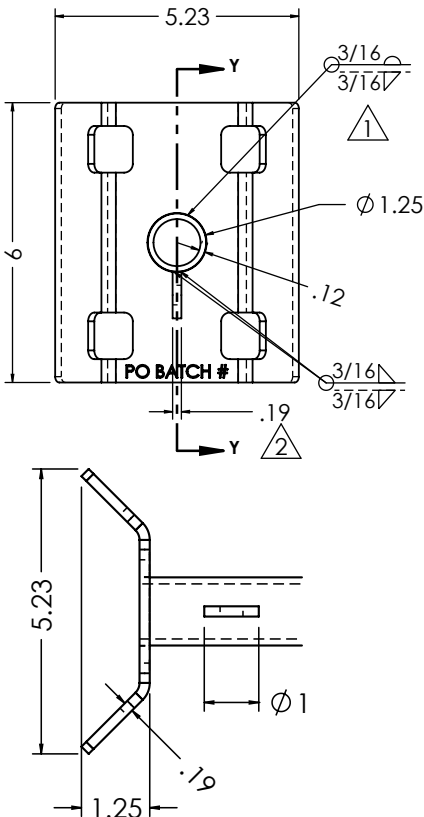

Dimensions (28" width banners):

- Total Length: 33.4" (848mm)
- Arm Length: 32.19" (818mm)
- Arm Diameter: 1.25" (32mm)
- Bracket Width: 5.23" (133mm)
- Bracket Depth: 1.25" (32mm)
- Banding Eyelets: 1" x 1" (25mm x 25mm)
- Weight: 5 lbs (2.3 kg)

To Specify:

- Banner arm length
- Natural galvanized for zinc-plated powder steel.



Classic Displays
Right for you since 1977